

# GENERAL SPECIFICATION OF HS-5665MH DIGITAL SUPER SPEED SERVO

## 1. TECHNICAL VALUES

CONTROL SYSTEM	:+PULSE WIDTH CONTROL 1500usec NEUTRAL, 900~2100us/20ms FRAME	
OPERATING VOLTAGE RANGE	:6.0V TO 7.4V	
OPERATING TEMPERATURE RANGE	:-20 TO +60°C(-4°F TO +140°F)	
TEST VOLTAGE	:AT 6.0V	: AT 7.4V
OPERATING SPEED	:0.16sec/60° AT NO LOAD	: 0.14sec/60° AT NO LOAD
STALL TORQUE	:8.8kg.cm(122.2oz.in)	:10.00kg.cm(138.87oz.in)
STANDING TORQUE	:-	
IDLE CURRENT	:6mA	:7mA
RUNNING CURRENT	:280mA	:350mA
STALL CURRENT	:2100mA	:2600mA
DEAD BAND WIDTH	:4usec	
OPERATING ANGLE	:40°/ONE SIDE PULSE TRAVELING 400usec	
DIRECTION	:CLOCK WISE/PULSE TRAVELING 1500 TO 1900usec	
MOTOR TYPE	:3-POLE MOTOR	
POTENTIOMETER TYPE	:4 SLIDER/1M CYCLE LONG LIFE/INDIRECT DRIVE	
AMPLIFIER TYPE	:ATMEGA8 DIGITAL AMPLIFIER WITH MOSFET DRIVE	
DIMENSIONS	:40.6x19.8x37.8mm(1.59x0.77x1.48in)	
WEIGHT	:57g(2.01oz)	
BALL BEARING	:DUAL/MR106	
GEAR MATERIAL	:3 Metal gears & 1 MP first gear	
HORN GEAR SPLINE	:24 SEGMENTS/ø5.76	
SPLINED HORNS	:HEAVY DUTY/HD-IS, HD-O, HD-LS, HD-IL, HD-LL	
CONNECTOR WIRE LENGTH	:300mm(11.81in)	
CONNECTOR WIRE STRAND COUNTER	:0.08X60EA	
CONNECTOR WIRE GAUGE	:22AWG	

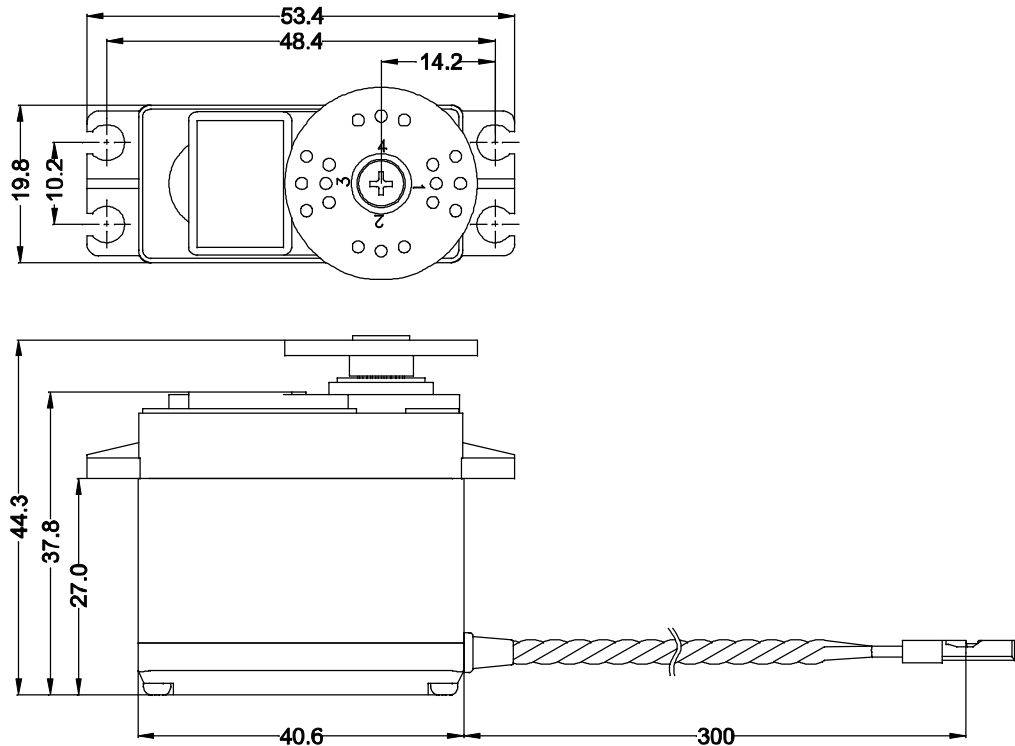

## 2. FEATURES

- DIGITAL & MOS FET AMP
- PROGRAMABLE
- GOLD PLATED CONTACTOR
- NARROW DEAD BAND WIDTH AND HIGH STANDING TORQUE
- SIX ADJUSTABLE SPLINED HORN

## 3. APPLICATIONS

- 30 SIZE HELICOPTERS
- GAS & ELECTRIC CARS
- BOATS