

# GENERAL SPECIFICATION OF D625MW DIGITAL SUPER SPEED SERVO

## 1. TECHNICAL VALUES

CONTROL SYSTEM	:+PULSE WIDTH CONTROL 1500usec NEUTRAL, 900~2100us/20ms FRAME		
OPERATING VOLTAGE RANGE	: 4.8V TO 7.4V		
OPERATING TEMPERATURE RANGE	:-20 TO +60°C(-4°F TO +140°F)		
TEST VOLTAGE	: AT 4.8V	: AT 6.0V	: AT 7.4V
OPERATING SPEED	: 0.20sec/60°	: 0.15sec/60°	: 0.13sec/60°
STALL TORQUE	: 6.3kg.cm(87.452oz.in)	: 8.8kg.cm(122.20oz.in)	: 10.0kg.cm(138.87oz.in)
STANDING TORQUE	:-		
IDLE CURRENT	: 30mA	: 30mA	: 30mA
RUNNING CURRENT	: 300mA	: 400mA	: 500mA
STALL CURRENT	: 1700mA	: 2150mA	: 2650mA
DEAD BAND WIDTH	: 2usec		
OPERATING ANGLE	: 40°/ONE SIDE PULSE TRAVELING 400usec		
DIRECTION	: CLOCK WISE/PULSE TRAVELING 1500 TO 1900usec		
MOTOR TYPE	: 3-POLE MOTOR		
POTENTIOMETER TYPE	: 4 SLIDER/1M CYCLE LONG LIFE/INDIRECT DRIVE		
AMPLIFIER TYPE	: STM32 DIGITAL AMPLIFIER WITH MOSFET DRIVE		
DIMENSIONS	: 40.6x19.8x37.8mm(1.59x0.77x1.48in)		
WEIGHT	: 60g(2.11oz)		
BALL BEARING	: DUAL/MR106		
GEAR MATERIAL	: 3 Metal gears & 1 MP first gear		
HORN GEAR SPLINE	: 25 SEGMENTS/∅6.0		
SPLINED HORNS	: HEAVY DUTY/HD-IS25, HD-OS25, HD-LS25, HD-IL25, HD-LL25		
CONNECTOR WIRE LENGTH	: 300mm(11.81in)		
CONNECTOR WIRE STRAND COUNTER	: 0.08X60EA		
CONNECTOR WIRE GAUGE	: 20AWG		

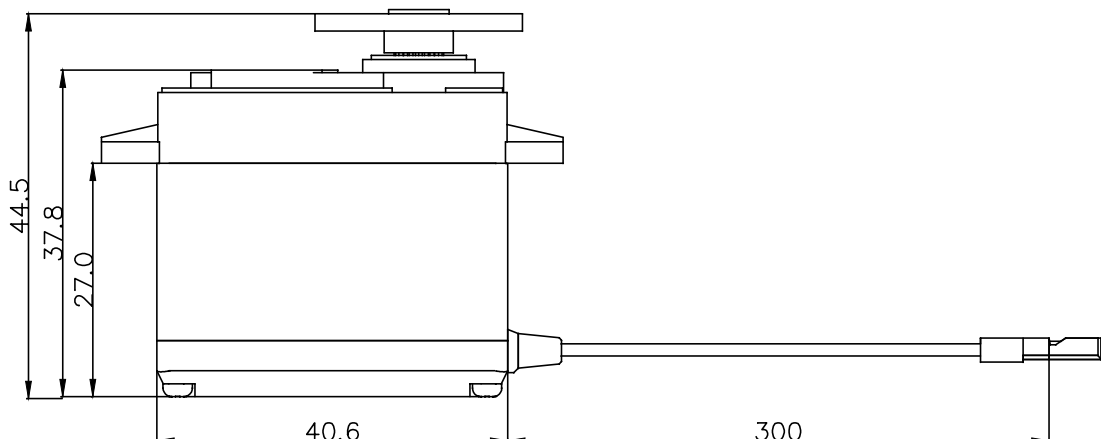
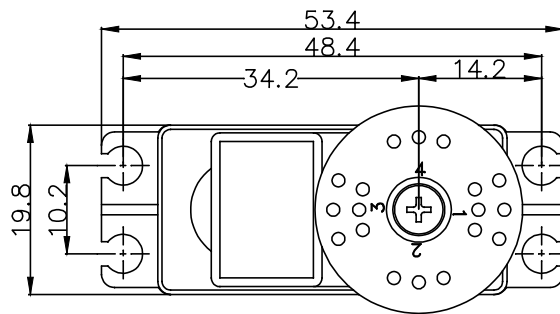

## 2. FEATURES

DIGITAL & MOS FET AMP  
PROGRAMABLE  
GOLD PLATED CONTACTOR  
NARROW DEAD BAND WIDTH AND HIGH STANDING TORQUE

## 3. APPLICATIONS

30 SIZE HELICOPTERS  
GAS & ELECTRIC CARS  
BOATS