

ANNOUNCED SPECIFICATION OF HS-7940TH HIGH VOLTAGE DIGITAL SERVO

1. TECHNICAL VALUE

CONTROL SYSTEM	:+PULSE WIDTH CONTROL 1500usec NEUTRAL	
OPERATING VOLTAGE RANGE	:6.0V TO 7.4V	
OPERATING TEMPERATURE RANGE	:-20°C TO +60°C(-4°F TO +140°F)	
TEST VOLTAGE	:6.0V	AT 7.4V
OPERATING SPEED	:0.07sec/60° AT NO LOAD	0.06sec/60° AT NO LOAD
STALL TORQUE	:13.0kg.cm(180.53oz.in)	16.0kg.cm(222.19oz.in)
STANDING TORQUE	:-	
IDLE CURRENT	:10mA AT STOPPED	10mA AT STOPPED
RUNNING CURRENT	:390mA/NO LOAD RUNNING	500mA/NO LOAD RUNNING
STALL CURRENT	:4,800mA	6,200mA
DEAD BAND WIDTH	:1usec	1usec
OPERATING TRAVEL	:ONE SIDE PULSE TRAVELING 400usec	
DIRECTION	:CLOCK WISE/PULSE TRAVELING 1500 TO 1900usec	
MOTOR TYPE	:CORELESS METAL BRUSH	
POTENTIOMETER TYPE	:4 SLIDER/1M CYCLE LONG LIFE/INDIRECT DRIVE	
AMPLIFIER TYPE	:ATMEGA48 MCU DIGITAL AMPLIFIER WITH MOSFET DRIVE	
DIMENSIONS	:40x20x38mm(1.57x0.79x1.50in)	
WEIGHT	:68g(2.40oz)	
BALL BEARING	:DUAL/MR106	
GEAR MATERIAL	:1 METAL-PLASTIC & 3 TITANIUM ALLOY	
HORN GEAR SPLINE	:24 SEGMENTS/ø5.76	
SPLINED HORNS	:HEAVY DUTY/HD-IS, HD-O, HD-LS, HD-IL, HD-LL	
CONNECTOR WIRE LENGTH	:300mm(11.81in)	
CONNECTOR WIRE STRAND COUNTER	:80EA	
CONNECTOR WIRE GAUGE	:20AWG	

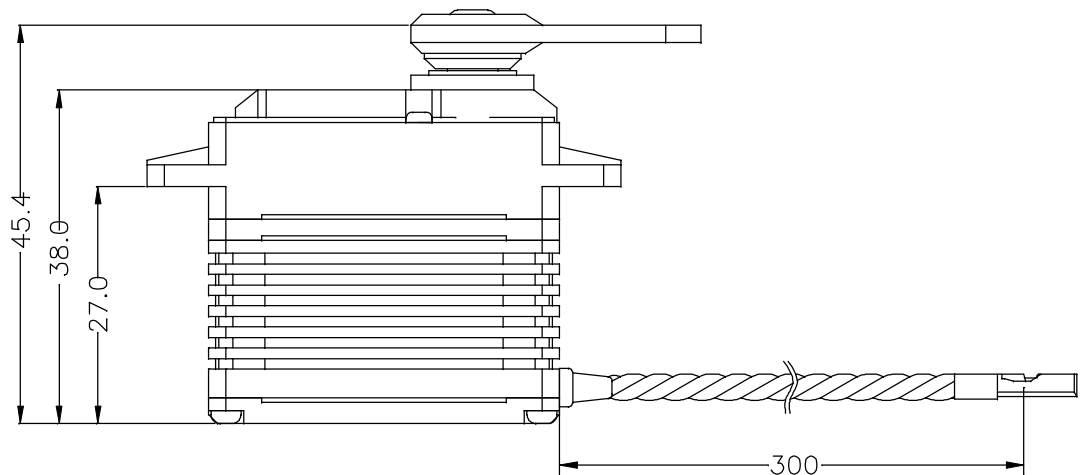
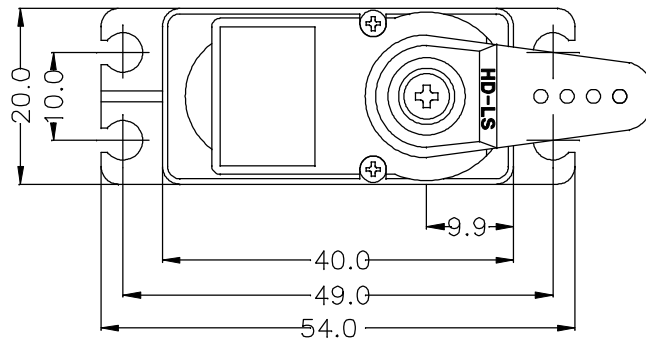

2. FEATURES

- PROGRAMMABLE DIGITAL AMPLIFIER WITH MOSFET DRIVE
- DURABLE TITANIUM ALLOY METAL GEARS WITH DUAL BALL BEARING
- ULTRA HARDNESS GEAR SHAFT WITH 3 AXIAL METAL BUSHING
- WATER & DUST RESISTANCE
- HEAT SINK FOR MOTOR

3. APPLICATIONS

- LARGE AIR PLANE MODELS