

GENERAL SPECIFICATION OF HS-8330SH HIGH VOLTAGE DIGITAL SERVO

1. TECHNICAL VALUE

CONTROL SYSTEM	:+PULSE WIDTH CONTROL 900~2100us,1500us NEUTRAL	
OPERATING VOLTAGE RANGE	:6.0V TO 7.4V	
OPERATING TEMPERATURE RANGE	:−20°C TO +60°C(−4°F TO +140°F)	
TEST VOLTAGE	:AT 6.0V	AT 7.4V
OPERATING SPEED	:0.085sec/60° AT NO LOAD	0.07sec/60° AT NO LOAD
STALL TORQUE	:10.0kg.cm(138.87oz.in)	13.0kg.cm(180.53oz.in)
STANDING TORQUE	:−	
IDLE CURRENT	:8mA AT STOPPED	10mA AT STOPPED
RUNNING CURRENT	:400mA/NO LOAD RUNNING	500mA/NO LOAD RUNNING
STALL CURRENT	:4,200mA	5,200mA
DEAD BAND WIDTH	:1us	1us
OPERATING TRAVEL	:40±5°/ONE SIDE PULSE TRAVELING 400usec	
DIRECTION	:CLOCK WISE/PULSE TRAVELING 1500 TO 1900usec	
MOTOR TYPE	:CORELESS METAL BRUSH	
POTENTIOMETER TYPE	:1M CYCLE LONG LIFE/INDIRECT DRIVE	
AMPLIFIER TYPE	:DIGITAL AMPLIFIER WITH MOSFET DRIVE	
DIMENSIONS	:40x20x37mm(1.57x0.78x1.45in)	
WEIGHT	:66.0g(2.32oz)	
BALL BEARING	:DUAL/MR106	
GEAR MATERIAL	:1 METAL-PLASTIC & 3 STEEL GEARS	
HORN GEAR SPLINE	:25 SEGMENTS/∅6.00	
SPLINED HORNS	:HEAVY DUTY/IM25, LS25, OS25, X25	
CONNECTOR WIRE LENGTH	:300mm(11.81in)	
CONNECTOR WIRE STRAND COUNTER	:80EA	
CONNECTOR WIRE GAUGE	:20AWG	

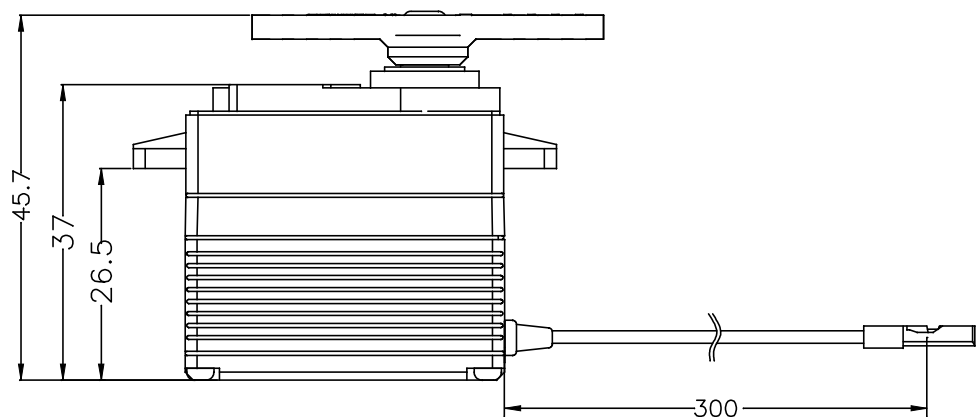
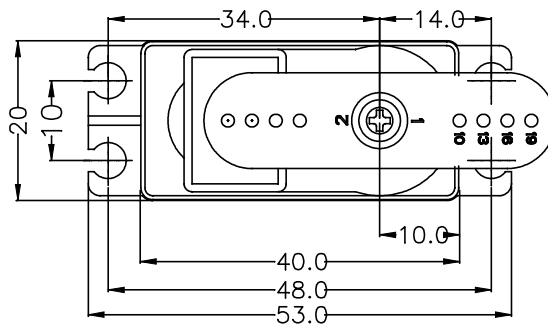

2. FEATURES

HIGH VOLTAGE & RESPONSE DIGITAL SERVO
 DURABLE STEEL GEARS WITH DUAL BALL BEARING
 ULTRA HARDNESS GEAR SHAFT WITH 3 AXIAL METAL BUSHINGS
 HEAT SINK FOR MOTOR
 WATER & DUST RESISTANT
 3mm HORN SCREW("+" & HEX SOCKET SCREW INCLUDE)
 APPLIED H25T HORN GEAR

3. APPLICATIONS

AIRCRAFT 20~120 CLASS
 ALL EP 600~700 & GP 30~90 CLASS HELICOPTERS
 1/10 ~ 1/4 SCALE CAR STEERING & THROTTLE
 NITRO & GASOLINE BOATS

HITEC RCD KOREA INC.